









## Caractéristiques techniques - Technical specifications :

- **Façades et côtés en PPSM ép. 16 mm décor**
- Fronts and sides made of 16 mm decorative PPSM
- **Structure en PPSM ép.16mm décor, classe E1/P2**
- Structure in 16 mm melamine-faced chipboard (MFC), E1/P2 grade
- **Plan-vasque moulé en une seule pièce avec remontée arrière en SMO™ : composite poudre de pierre et résine polyester revêtu d'un gelcoat**
- One-piece moulded SMO™ washbasin top with rear upstand: stone powder and polyester resin composite coated with gelcoat

## Conseils et recommandations - Tips and recommendations

	<p><b>Déballiez soigneusement en prenant garde de ne pas rayer les produits avec un cutter et inspectez les meubles avant installation. Signalez tout défaut avant l'installation, aucune réclamation ne sera acceptée après la pose.</b></p>	<p>Carefully unpack the units, avoiding scratches from cutters, and inspect all components before installation. Report any defects prior to installation — no claims will be accepted after the unit has been fitted.</p>
	<p><b>Protégez le sol pour ne pas risquer de rayer les meubles. Les miroirs et les plans de toilette sont des objets fragiles, il est recommandé de les poser au sol sur des tasseaux entre chaque manipulation.</b></p>	<p>Protect the floor surface to avoid scratching the furniture. Mirrors and washbasin tops are fragile and should be placed on wooden battens when handled.</p>
	<p><b>Assurez l'étanchéité avec un silicone sanitaire pour éviter tout dommage non couvert par la garantie.</b></p>	<p>Ensure proper sealing with sanitary-grade silicone to avoid damage not covered by the warranty.</p>
	<p><b>Essuyez rapidement l'eau stagnante et ventilez la salle de bains pour préserver les meubles.</b></p>	<p>Wipe off any standing water promptly and ventilate the bathroom to preserve the furniture.</p>
	<p><b>La pose doit être effectuée par un professionnel qualifié pour garantir la conformité.</b></p>	<p>Installation must be carried out by a qualified professional to ensure compliance and safety.</p>

## Conseils d'entretien - Maintenance advice

-  ✓ torchon  
cloth
-  ✓ éponge non abrasive  
non-abrasive sponge
-  ✓ savon neutre  
mild soap
-  ✓ eau froide ou tiède  
cold or warm water

## Protégez-vous - Protect yourself



## Outillage non fourni - Tools not supplied



## Quincaillerie fournie - Hardware supplied

<b>Pattes murales standards</b> - Standard wall plates	<b>Poignée</b> - Handle	<b>Vis pour fixer la poignée</b> - Screws to attach the handle	<b>Vis d'assemblage</b> - Assembly screws*	<b>Cache accroche meuble</b> - Cover cap **
				

**\*Dans le cas où le meuble est composé de deux caissons.**

If the unit is made of two carcasses.

**\*\*Cache accroche livré pour rangement porte.** Hanger cover supplied for door units.

**Les vis et les chevilles pour fixer les pattes murales au mur ne sont pas fournies.**

Screws and wall plugs for fixing the wall brackets to the wall are not supplied.

# MEUBLE VASQUE - BASIN UNIT

## HAUTEUR D'INSTALLATION - INSTALLATION HEIGHT

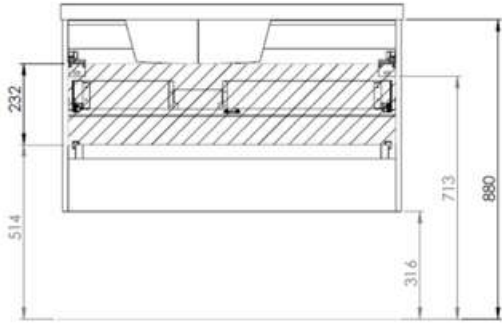

## VIDE SANITAIRE - PLUMBING VOID

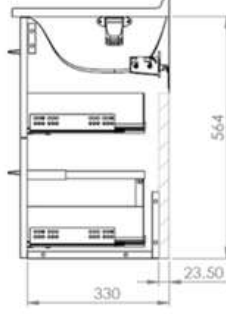

## PROFIL VASQUE - BASIN PROFILE

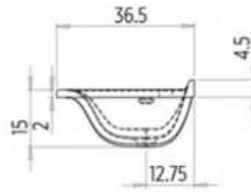

Hauteur d'évacuation  
- Drain outlet height

# COLONNE - TALL UNIT

## HAUTEUR D'INSTALLATION - INSTALLATION HEIGHT

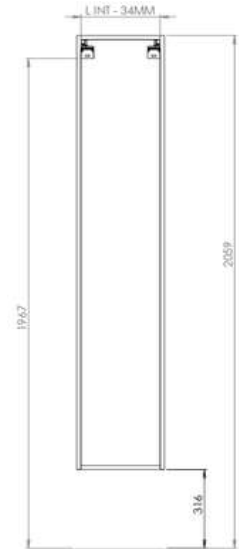

**Pour la pose de la colonne, suivre les étapes 1, 2, 3, 4, 5, 10 et 11.**  
For the installation of the tall unit, follow steps 1, 2, 3, 4, 5, 10 and 11.

## 1 FIXER LES PATTES MURALES - FIX THE WALL PLATES

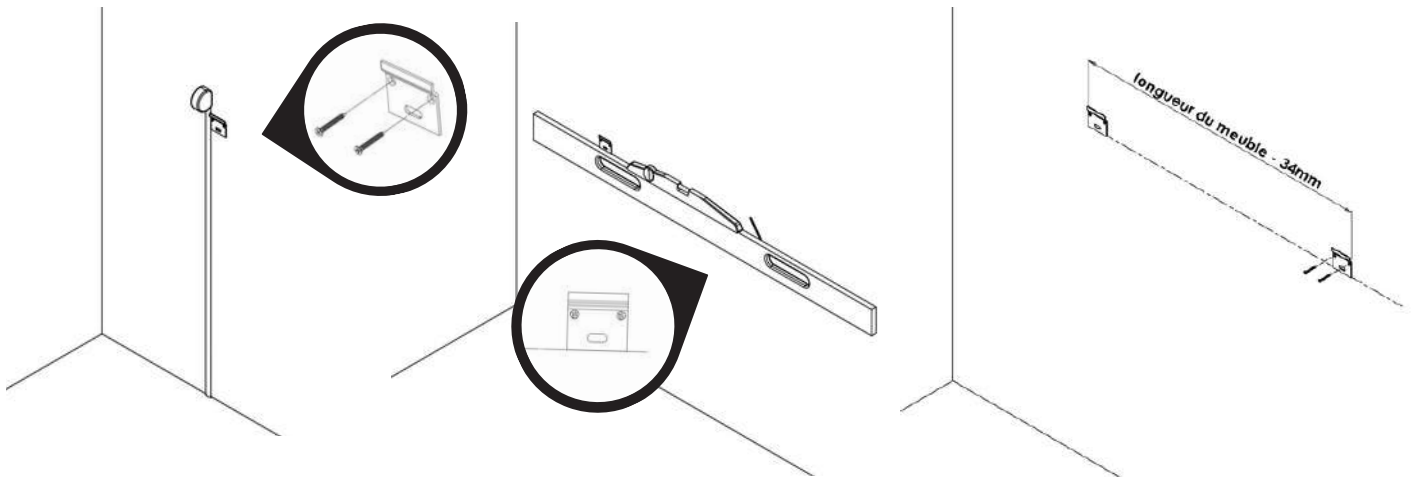

- Déterminer la hauteur et fixer la première patte
- Déterminer la hauteur de la deuxième patte
- Fixer la deuxième patte
- Determine the height and fix the first plate
- Place the second wall plate aligning it with the first one
- Drill and fix the second plate

## 2 RETIRER LES TIROIRS - REMOVE THE DRAWERS

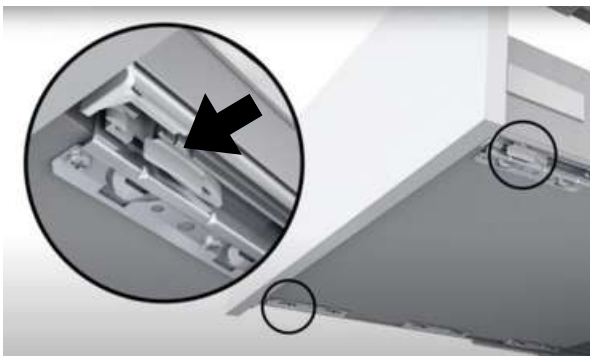

**CONSEIL :**  
Utiliser des cales pour poser le meuble sur le sol  
**CAUTION :**  
Use wedges to put the unit on the floor

- Ouvrir le tiroir et pousser les languettes grises
- Soulever et retirer le tiroir
- Open the drawer and press the grey tabs
- Lift and remove the drawer

## RETIRER LES PORTES - DISASSEMBLY THE DOORS

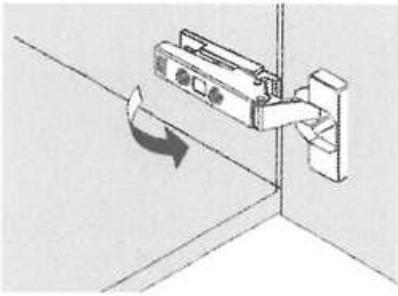

- **Attraper la charnière par le clapet arrière et tirer vers l'avant (Ne jamais démonter l'embase)**
- Grab the hinge by the rear flap and pull it forward (Never disassemble the hinge base).

## 3 DESSERRER LES ACCROCHE-MEUBLES - LOOSEN THE WALL HANGING BRACKETS

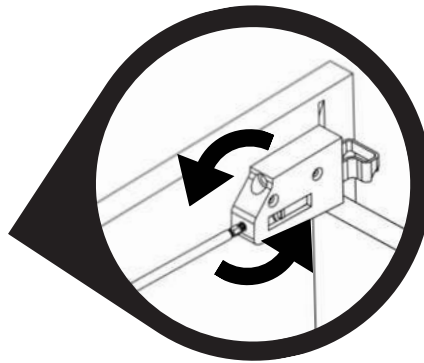
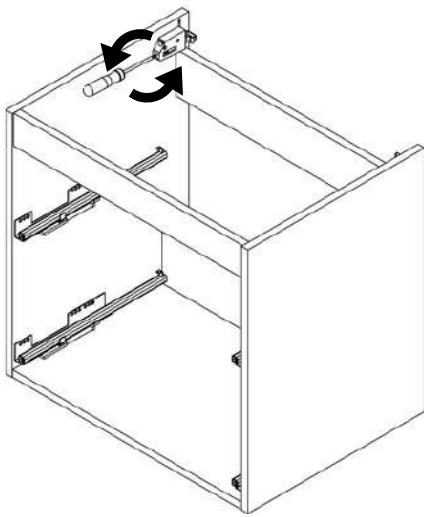

- **À l'aide d'un tournevis, desserrer les accroche-meubles**
- Using a screwdriver, loosen the wall hanging brackets

## 4 SUSPENDRE LE MEUBLE SUR LES PATTES - HANG THE UNIT ON THE WALL PLATE

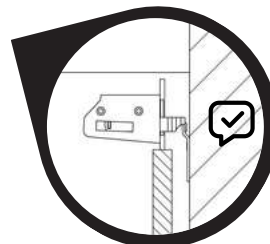
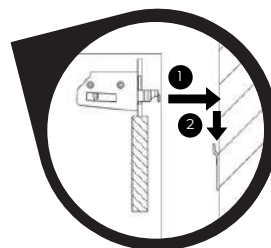
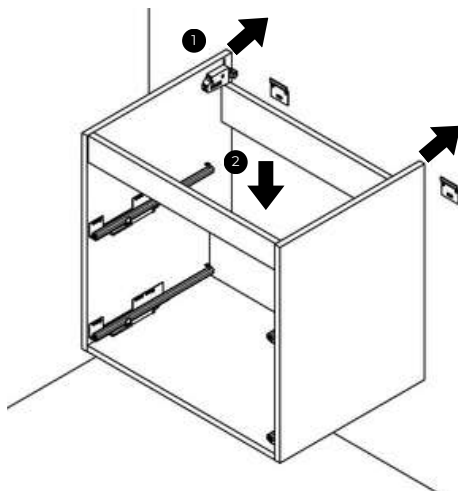

- **Accoler le meuble au mur (1)**
- Place the cabinet against the wall (1)

- **Enclencher l'accroche-meuble à la patte murale (2)**
- Engage the wall hanger onto the wall plate (2)

5

## SERRER LES ACCROCHES-MEUBLES - FIX THE UNIT ON THE WALL

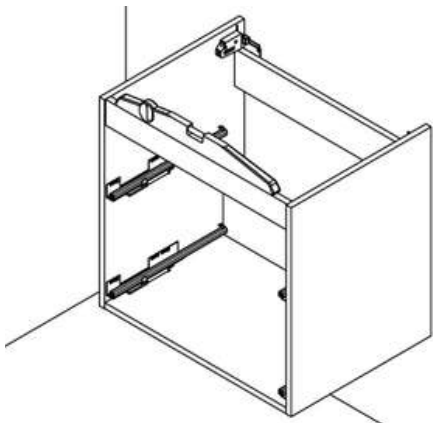

- **Serrer partiellement les accroche-meubles pour faire plaquer le meuble au mur (1)**
- Partially tighten the wall hangers to press the cabinet against the wall (1)

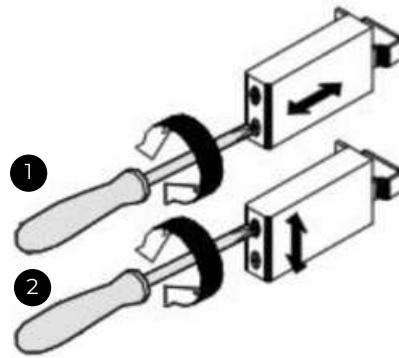

- **Contrôler les niveaux, régler le niveau à l'aide des accroche-meubles (2)**
- Check levels, adjust the level using the wall hangers (2)

## 6 POUR UN MEUBLE COMPOSÉ DE PLUSIEURS CAISSONS -FOR A UNIT COMPOSED OF MULTIPLE CABINETS

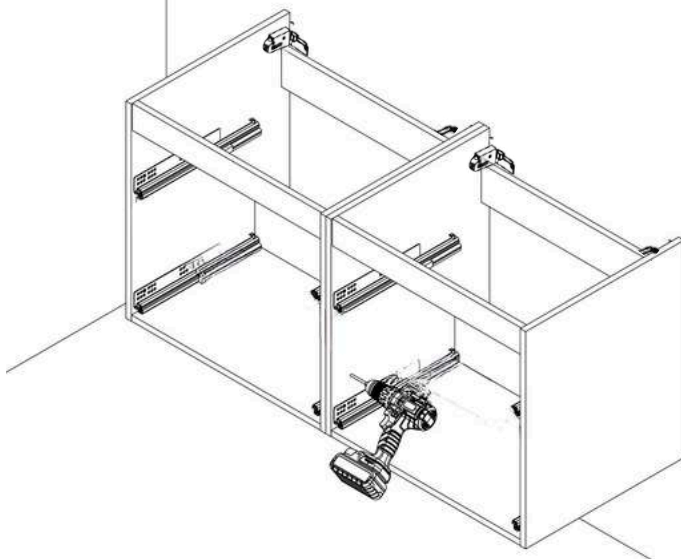

- **Privilégier des zones non visibles (ex. : derrière les coulisses)**
- **Visser les vis à bois**
- Prefer non-visible areas (behind the drawer runners)
- Insert wood screw

7

## POSER LE TROP-PLEIN FOURNI -INSTALL THE SUPPLIED OVERFLOW

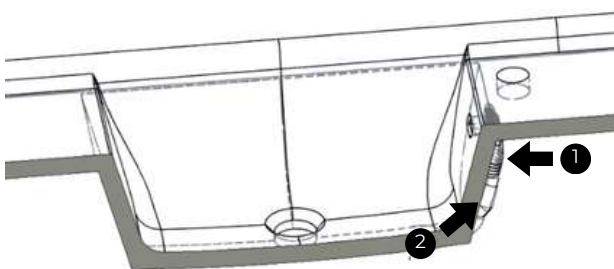

- **La vasque est fournie avec un enjoliveur de trop-plein intégré (1) (Ne pas utiliser l'enjoliveur rond fourni)**
- The basin is supplied with an integrated overflow cover (1). (Do not use the round overflow cover provided.)
- **Raccorder l'enjoliveur au trop-plein fourni (2)**
- Connect the cover to the supplied overflow (2).

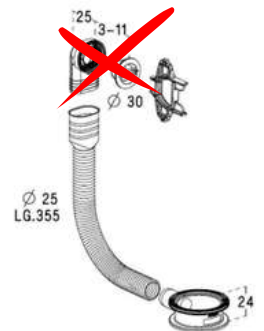
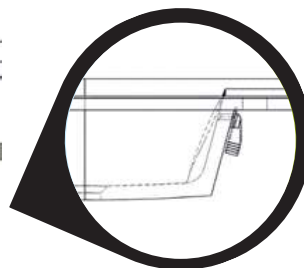

**Ne pas oublier de placer les joints d'étanchéité**  
Do not forget to fit the sealing gaskets.

**Il est conseillé de fixer le mitigeur après cette étape**

It is recommended to install the mixer tap after this step.

## 8 APPLIQUER LE SILICONE -APPLY SILICONE ON TOP AND SIDE OF UNIT

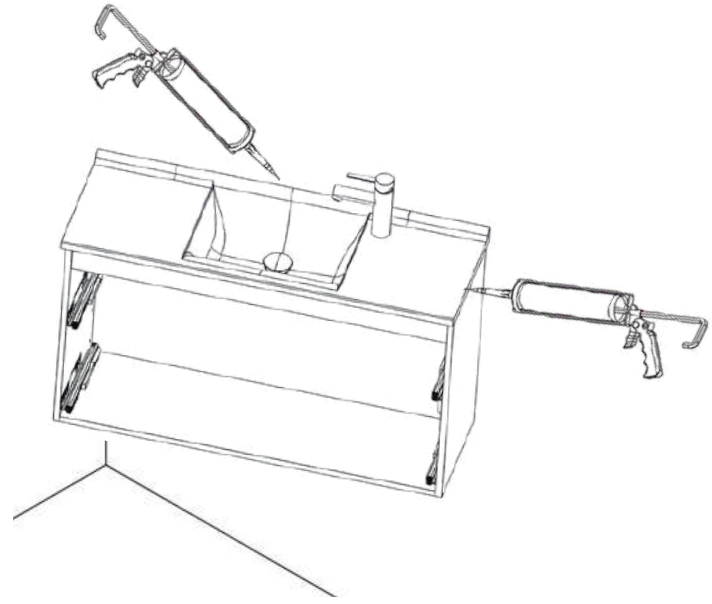
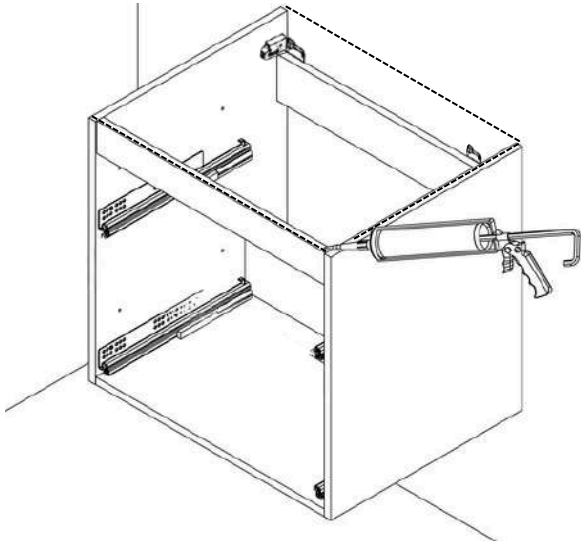

- Appliquer le silicone sur tout le dessus du meuble et sur le mur (épaisseur du plateau)
- Apply sanitary silicone along the top edge of the cabinet and the wall (matching the thickness of the top)

- Présenter le plateau, puis poser-le
- Appliquer les joints de finition
- Position the washbasin, then place it
- Apply the finishing joints

## 9 RACCORDER LA PLOMBERIE ET VÉRIFIER L'ABSENCE DE FUITE -CONNECTING THE PLUMBING, CHECK FOR LEAKS

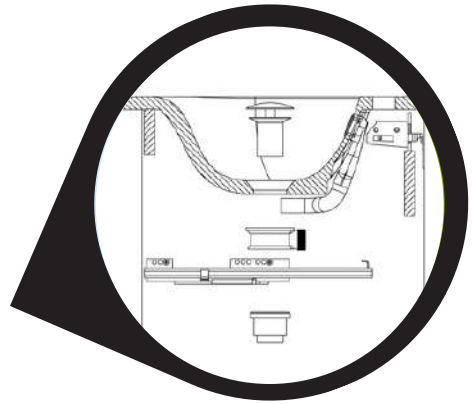
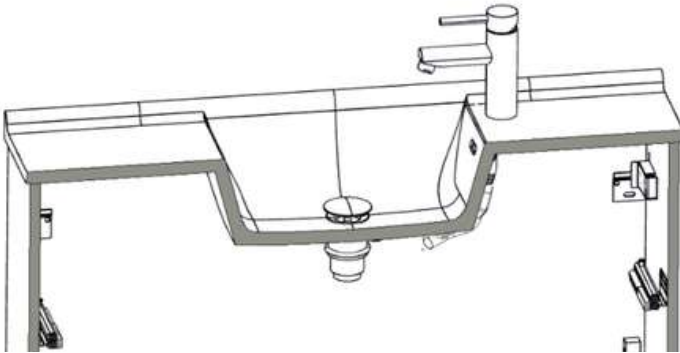

- Insérer la bonde (non fournie)
- Raccorder le trop-plein, puis visser la bonde
- Raccorder le siphon à l'évacuation (collage)
- Visser le siphon à la bonde

*Serrage manuel uniquement*

Les raccords et les éléments sont donnés à titre d'exemple.

- Insert the waste (not supplied)
- Connect the overflow, then tighten the waste
- Glue the trap to the drain outlet
- Screw the trap to the waste

*Hand tightening only*

*Connections and elements shown are for illustration purposes only.*

# 10 POSITIONNER ET RÉGLER LES TIROIRS - INSTALL AND ADJUST THE DRAWERS

## MONTER LES TIROIRS - INSTALL THE DRAWERS



- **Rentrer les coulisses**
- Insert the drawer slides

- **Enfoncer le tiroir jusqu'à l'enclenchement**
- Push the drawer in until it clicks into place

## RÉGLER LES TIROIRS - ADJUST THE DRAWERS



- **Déclipser le cache tiroir**
- Unclip the drawer cover

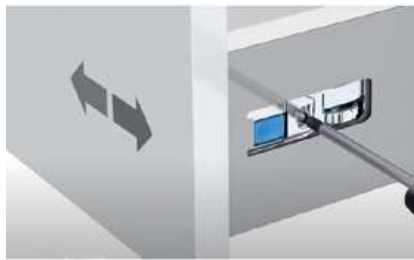

- **Pour régler latéralement de +/- 1,5mm**
- For lateral adjustment of +/- 1.5 mm

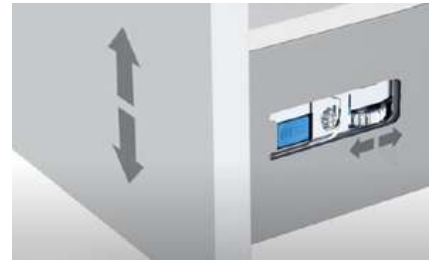

- **Pour régler la hauteur de +/- 2mm**
- For height adjustment of +/- 2 mm

### Réglage valable lorsque le tiroir est composé de ridelles

Adjustment applicable when the drawer has side panels

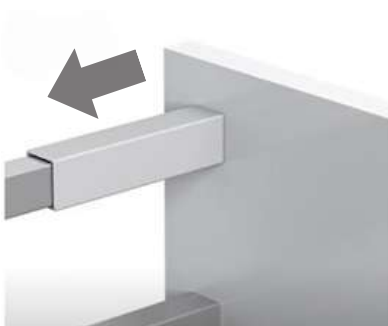

- **Retirer le cache**
- Remove the cover

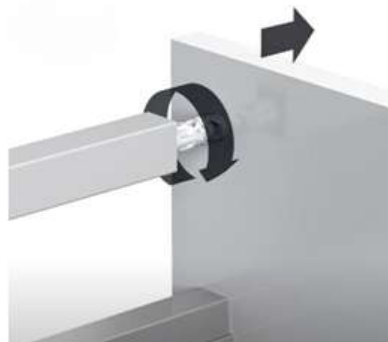

- **À l'aide d'un tournevis Faire avancer la façade**
- Using a screwdriver, move the front panel forward

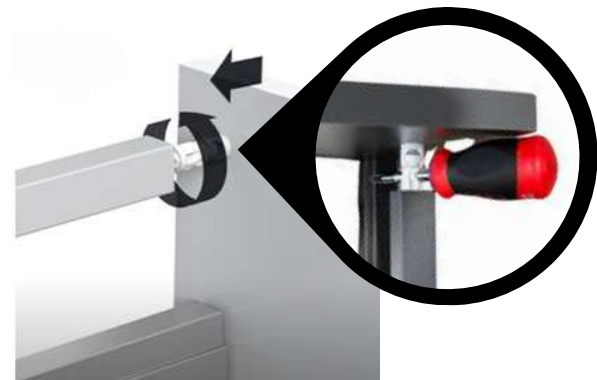

- **À l'aide d'un tournevis Faire reculer la façade**
- Using a screwdriver, move the front panel backward

## MONTER LES PORTES - ASSEMBLY THE DOORS

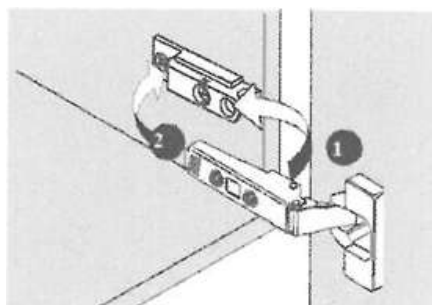

- **Emboîter (1) rabattre et clipser (2)**

- Insert (1), fold down and snap into place (2).

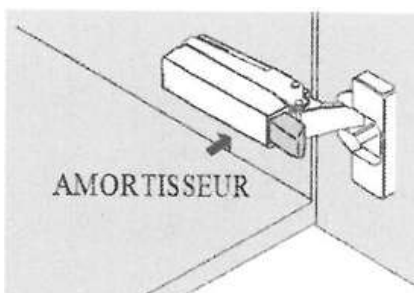

- **Après réglage, placer 1 amortisseur par porte et non 1 par charnière**

- **Placer les caches sur les autres charnières**

- After adjustment, place one damper per door, not one per hinge.

- Place the covers on the other hinges.

## RÉGLER - ADJUST

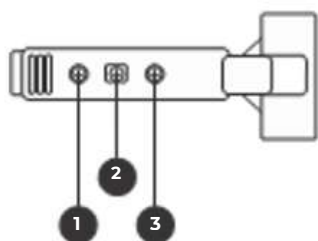

- **Sur chaque charnière il y a 3 vis de réglage**

- Each hinge has 3 adjustment screws

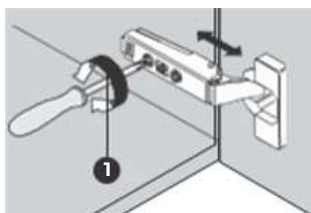

- **1 : régler en profondeur**

- 1: Depth adjustment

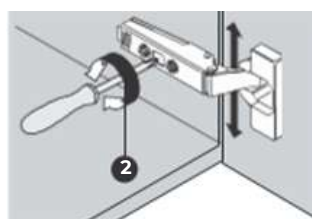

- **2 : régler en hauteur**

- 2: Height adjustment

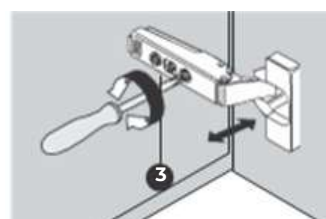

- **3 : régler latéralement**

- 3: Lateral adjustment

## 11 FIXER LES POIGNÉES - INSTALL THE HANDLES

**Normes** - Standards compliance

**Meubles sont conformes à la norme NF 022 - NF AMEUBLEMENT MOBILIER DOMESTIQUE** - Furniture complies with NF 022 - NF Domestic Furniture Standard

**Plans-vasque conformes à la norme NF EN 14688 - APPAREIL SANITAIRE - LAVABOS** - Washbasin tops comply with NF EN 14688 - Sanitary appliances - Washbasins

**Cette notice est destinée à faciliter le montage du meuble, elle n'est pas contractuelle.**

This guide is provided to facilitate installation and is not legally binding.